

THE HEAT PUMP REFERENCE GUIDE

Renewal and Enhancement of the 4th Edition Heat Pump Reference Guide

Final Guide

Prepared for: CEA Technologies Inc.
1155 Metcalfe Street, Suite 1120
Montreal, QC
H3B 2V6

Prepared by: Caneta Research Inc.
7145 West Credit Avenue
Suite 102, Building 2
Mississauga, Ontario
L5N 6J7

March 27, 2007

TABLE OF CONTENTS

Section	Page
The Heat Pump Reference Guide	1
1 Scope	1
2 What is a Heat Pump?	3
How do Heat Pumps Work?	3
Are There Gas Heat Pumps?	4
3 What To look for in Buying a Heat Pump?	7
Critical Information	7
Choosing a Contractor	7
4 Components	9
Compressor	9
Heat Exchanger Coils (Evaporator/Condenser)	9
Electronically Commutated Blower Motors (ECMs)	10
Reversing Valve	10
Expansion Device	10
Defrost Sensor and Control	11
Accumulator	12
Crankcase Heater	12
Refrigerant	12
5 Operating Cycles	15
Heating Cycle	15
Cooling Cycle	16
Defrost Cycle	16
Absorption Heat Pump Heating Cycle	17
Domestic Water Heating	17
New Developments in Heat Pump Technology	18
6 Definitions and Standards	21

Table of Contents

Efficiency Definitions	21
Performance Standards	22
Estimating Energy Savings	25
7 What is the Difference between Types of Heat Pumps?	31
Problems with Classifications	32
System versus Hardware	33
Variations of a Heat Pump	33
Air-Source Systems	33
Ground-Source Systems	44
Other Heat Pump Types	53
Integrated Systems	59
Multi-Source Systems	60
8 Installation Considerations	61
Air-Source Heat Pumps	61
Ground-Source Heat Pumps	62
What can go Wrong with a Heat Pump?	63
9 Frequently Asked Questions	65
10 Heat Pump Training Programs	67
11 Manufacturers	69

1 SCOPE

- The guide explains how a heat pump works, the important considerations in buying a heat pump, the components that make up a heat pump, the different operating cycles, the efficiency definitions, performance standards used by industry and what influences energy savings.
- The guide goes into greater depth describing the characteristics of the wide range of heat pumps in the market for residential, commercial and industrial heating and cooling applications.
- Installation considerations, what goes wrong with heat pumps, training programs, frequently asked questions with answers and a directory of heat pump manufacturers are included as well.
- The guide has a North American scope covering both US and Canadian standards, industry associations and information sources.

2 WHAT IS A HEAT PUMP?

How do Heat Pumps Work?

- Figure 1 shows a simple heat pump cycle diagram.
- Heat is absorbed at the evaporator from a heat source and the refrigerant changes from a low-pressure liquid to a low-pressure gas.
- The low-pressure gas is compressed into a high-pressure gas by a compressor.
- Heat is released in the condenser and delivered to the heat sink. The vapour condenses to a high-pressure liquid as it gives up heat.
- The high-pressure liquid is expanded through the expansion valve to become a low pressure liquid and the cycle is repeated.
- A heat pump actually delivers more heat output than the equivalent of the electric input it uses. It is not uncommon for a heat pump to deliver 250% to 400% more heat than you would obtain from an equivalent electric resistance heating system.
- The most common heat pumps use electrically-driven compressors.

2 What is a Heat Pump?

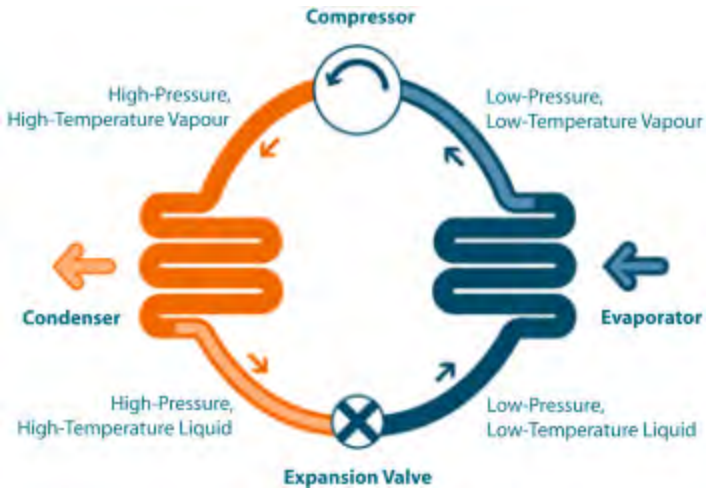

Figure 1: Heat Pump Cycle Diagram

4

Are There Gas Heat Pumps?

- Heat pumps fired by natural gas have been commercially developed.
- One type uses the absorption cycle, where the energy for refrigerant compression is provided by a gas burner.
- Another variation is the engine-driven heat pump cycle. Here a natural gas engine is used to drive the compressor. During operation, heat is recovered from the engine jacket cooling water and engine exhaust.
- Gas heat pumps are less common than electric heat pumps.
- Performance compared to electric heat pumps is lower, with lower COPs for both absorption and engine-driven units than for conventional electric heat pumps.

- The inherent variable-speed capability of an engine offers part-load efficiency advantages compared to single speed electric compressor drives.
- They promise to reduce global warming through more efficient conversion of natural gas and reduced emissions from electric power plants as they do not use electricity to drive the heat pump.

3 WHAT TO LOOK FOR IN BUYING A HEAT PUMP?

Critical Information

A heat pump must be sized absolutely correctly or it simply won't produce the benefits the buyer expects. In the case of a ground source heat pump, this also applies to the ground heat exchanger. The heat pump or system must than be installed properly or it won't operate satisfactorily. Look to industry standards for applicable guidance on design and installation of heat pump systems. The reader is encouraged to review Chapter 8, Installation Considerations for additional critical information at the time of heat pump purchase.

An installation must not be accepted before receiving:

- an estimate of the heating and cooling requirements based on a recognized heat loss/heat gain calculation procedure and a recommended heat pump to meet those requirements;
- an examination of the adequacy of existing ductwork, electrical service and furnace(where applicable);
- a full and firm quotation on all aspects of the installation;
- an explanation of how the heat pump works, how to operate and maintain it and the types of warranties and maintenance contracts available;
- arrangements for electrical inspection to ensure that wiring is safely installed.

Choosing a Contractor

Finding a good contractor involves selecting someone that:

- is an authorized dealer for the equipment they sell;

3 What to look for in Buying a Heat Pump?

- has passed manufacturer training for installation and service of the unit;
- has certified refrigeration and electrical as required for the installation;
- guarantees the installation work;
- offers service contracts after manufacturer warranty expires;
- provides 24-hour service;
- itemizes everything that needs to be done and when in a contract;
- has references of past installations.

Arrange for at least three quotations to ensure the best price.

4 COMPONENTS

Compressor

- The compressor is the heart of the heat pump. It pumps refrigerant around the refrigerant circuit, and increases the pressure of the refrigerant vapour. This increase in pressure allows the refrigerant to condense (in the condenser coil) at a higher temperature.
- Refrigerant vapour always flows through the compressor in the same direction – it enters the suction pipe at low pressure and is discharged at a higher pressure.
- Compressor life averages between 15 and 20 years.
- Compressor warranties today are typically 10 years .
- Positive displacement compressors are the most common in heat pumps, and are of three types: reciprocating, rotary and scroll.

Heat Exchanger Coils (Evaporator/Condenser)

- The evaporator and condenser are coils that absorb or reject heat between two mediums of different temperatures.
- Because a heat pump can reverse its function (cooling or heating), each heat exchanger coil can be an evaporator or a condenser coil.
- In heating mode, the outdoor coil in an air-source heat pump or the water-coil in a ground-source heat pump absorbs while the condenser in the indoor air stream rejects heat.
- In cooling mode, the coil in the indoor air stream absorbs heat while the outdoor coil (water-coil in ground source heat pump) rejects the excess heat.

Electronically Commutated Blower Motors (ECMs)

- ECMs or brushless DC motors are more efficient than standard permanent split capacitor (PSC) blower motors, and are able to operate over a wider range of speeds with the same efficiency.
- These motors are often associated with top-of-the-line two-stage or multi-stage heat pumps of all types. It is common to require an ECM indoor blower drive to achieve SEER 13 or 14 today on most air-source heat pumps.
- When a dual capacity heat pump operates at low capacity, the ECM indoor blower uses about 30% of power needed by blower at high capacity.
- Air temperature at outlets is typically warmer with ECM blower equipped dual capacity heat pumps operating in high capacity mode.
- In circulation mode (no heating or cooling) power draw can be 100 watts or lower with an ECM blower motor compared to 300 to 400 watts with a PSC motor.

10

Reversing Valve

- Automatically controls the direction of refrigerant through the system for heating and cooling in all heat pumps and in defrost mode in air-source heat pumps.
- Its position is controlled by a heating/cooling thermostat in the home or the defrost control in an air-source heat pump during the defrost cycle.

Expansion Device

- Meters or regulates the flow of liquid refrigerant to the evaporator.
- Reduces pressure of the liquid refrigerant to enable vaporization, and therefore heat absorption, to take place in the evaporator coil.
- There are two types of expansion devices used today: fixed flow area type (capillary and orifice) and thermostatic expansion (TEX) valve.
- TEX valves are used where there is a varying load on the evaporator. They are recommended over fixed flow types.
- Efficiency improvements of 5-10 % are claimed with electric expansion valves.

Defrost Sensor and Control

- Frost can accumulate on the outdoor coil of an air-source heat pump below 5°C.
- Frost impedes heat transfer between air and refrigerant and reduces capacity.
- Common methods of sensing and initiating defrost:
 - time/temperature** – after a pre-set compressor runtime and if the coil temperature is below a pre-set value, defrost is initiated.
 - Demand defrost** – either the presence of frost increases pressure drop across the outdoor coil or the temperature difference between the refrigerant and air can initiate a defrost cycle.
- In all cases the outdoor coil is defrosted by re-directing compressor heat to the outdoor coil to melt frost.
- Demand defrost reduces energy associated with defrost by 5 – 10% and is recommended over time/temperature defrost.

Accumulator

- A storage vessel that prevents excess liquid refrigerant from passing into the compressor, which could cause damage.
- This is especially important during the heating cycle when all refrigerant may not evaporate after passing through the evaporator coil.
- Scroll compressors, as compared to reciprocating, have a relatively high tolerance to liquid when slugging occurs.

Crankcase Heater

- Commonly used in air-source heat pumps.
- Used to raise the oil temperature in the compressor. Higher oil temperature causes refrigerant to vaporize and this prevents it from mixing with the crankcase oil.
- Diluting the oil would put more strain on the compressor due to the larger volume of liquid in the crankcase.
- Aids in starting in cold weather (better lubrication).

Refrigerant

- A liquid that has a low boiling point.
- There are several refrigerant manufacturers.
- Heat pumps still use R22 refrigerants. R22 performs well over the range of temperatures that heat pumps operate at.
- R22 is known as a hydrochlorofluorocarbon (HCFC) refrigerant and has an ozone depletion (ODP) factor of 0.05.

- Many heat pumps today use R-407C or R-410A, which are hydrofluorocarbons (HFC).
- Both R-407C and R-410A have zero ozone depletion potential (ODP), and slightly lower global warming potential (GWP) in the case of R-407C, than R-22. R410A has a slightly higher GWP than R22.
- Performance (heating capacity and efficiency) is about the same with R-407C and about 4% better with R410A compared to R-22.
- R-22 will be phased out for new equipment by January 1, 2010.

5 OPERATING CYCLES

- Rules of thumb when dealing with liquids or gases:
 - as pressure increases, boiling point and condensing temperature increases;
 - as pressure decreases, boiling point decreases and condensing temperature decreases.
- All heat pumps operate in a similar manner in terms of the refrigerant boiling and condensing, pressure increasing and decreasing and the flow of refrigerant through the system.

Heating Cycle

- The evaporator coil absorbs heat from the heat source causing the refrigerant to boil.
- The compressor draws refrigerant vapour from the evaporator, which is then compressed to a higher pressure (causing the temperature to rise even more due to compression heat).
- The high-temperature refrigerant vapour is fed to the condenser where heat is absorbed by indoor air passing over the coil.
- This lowers the temperature of the vapour, causing it to condense to a liquid. The liquid refrigerant then passes through an expansion device that changes it from high pressure to low pressure.
- The low-pressure refrigerant moves into the evaporator coil where it is heated and the cycle will repeat.

Cooling Cycle

- In cooling mode, the reversing valve is energized, causing the refrigerant flow to change direction.
- The evaporator coil now becomes the condenser and the condenser coil becomes the evaporator. Heat is now absorbed by the evaporator as warm air passes over it. The condenser coil rejects heat.
- The refrigerant cycle is the same for both the heating and cooling modes. Only the role of the heat exchanger coils change.

Defrost Cycle

- Applies only to air-source heat pumps.
- In heating mode the outdoor evaporator coil often operates below 0°C (32°F). Moisture in the air causes frost to build up on the coil. This leads to reduced heat transfer, insufficient airflow and an overall reduction in efficiency.
- To remove frost build-up, the system is reversed (put in cooling mode) for a short time. The outdoor coil becomes a condenser and rejects heat that melts the frost. The cooling effect is not felt indoors during a defrost cycle because backup heat maintains the indoor temperature.
- Defrost control is automatic and performs well under most conditions. However, if the control malfunctions then the outdoor coil could become caked with ice or cause the defrost cycle to operate longer than necessary causing energy waste. A local service person should be consulted.

Absorption Heat Pump Heating Cycle

- Absorption equipment consists of a fluid pair such as ammonia-water. Water is the absorbent and ammonia is the refrigerant. The refrigerant vaporizes in the evaporator and is absorbed by the absorbent in the absorber.
- A natural gas burner provides heat input to boil the solution, causing the release of refrigerant vapour. The refrigerant vapour condenses, releasing its heat to the house and returns to the evaporator where the cycle is repeated.

Domestic Water Heating

- Some heat pumps are equipped with a device called a desuperheater.
- The desuperheater is a heat exchanger located between the compressor and the condenser heat exchanger.
- Domestic water is circulated from a domestic hot water storage tank through the desuperheater when the heat pump is operating in either heating or cooling mode.
- The hot refrigerant gas leaving the compressor gives up heat to the domestic water in the desuperheater.
- A desuperheater can supply typically 25% and more of the water heating required in a residential application.
- Some heat pumps can produce hot water on demand even if there is no space heating or cooling demand. Operating savings can be higher with these systems because more

water heating can be done than with desuperheater-only systems.

- Desuperheaters in heating dominated climates take away about 10-15% of the heating capacity of the heat pump that would otherwise be used for space heating.
- Desuperheaters increase the load on the ground heat exchanger in heating dominated climates.

New Developments in Heat Pump Technology

- There has been much major advancement in heat pump technology in recent years leading to more reliable and higher-efficiency heat pumps.
- Compressors
 - Many manufacturers have switched to scroll rotary compressors that are more efficient and reliable for heat pump applications.
 - A few manufacturers use variable-speed or two-step compressors because they can vary the capacity of the compressor to match the heating or cooling load precisely.
 - Other manufacturers use multiple-speed compressors that have discreet speed steps and therefore perform better in both heating and cooling functions.
- Controls
 - Electronic controls now play a major role in heat pumps. They maintain much more precise temperatures. Demand defrost is electronically controlled which leads to higher efficiency levels. Microprocessors are used on some models to control both variable-speed and two-step compressors and variable-speed blowers. Programmable thermostats are being

interconnected with this type of control. Systems of this type often incorporate diagnostics that enable service technicians to quickly pinpoint malfunctions.

- Heat Exchanger Coils
 - Some newer models of air-source heat pumps have coils with more efficient and much larger heat transfer surfaces to increase heat transfer performance.

- Thermostats
 - The majority of thermostats for use with heat pumps today are electronic. These units maintain the room temperature closer to the set point, preventing the wider swings common to yesterday's mechanical thermostats thus allowing better comfort and energy efficiency.

6 DEFINITIONS AND STANDARDS

Efficiency Definitions

Coefficient of performance (COP)

$$\text{COP} = \frac{\text{energy output (heating)}}{\text{energy input}}$$

$$\text{or} \quad \frac{\text{heating capacity in Btu/hour}}{\text{energy input in watts} \times 3.413 \text{ Btu/watt} - \text{hour}}$$

- Where energy output and energy input refer to the heat pump unit only.
- The higher its COP value, the more efficient the unit.
- As outdoor temperatures decrease, COP values also decrease (during heating cycle), due to the extra work involved to absorb the same amount of heat from a cooler heat source.

Energy efficiency ratio (EER)

$$\text{EER} = \frac{\text{energy output in Btu/hour}}{\text{energy input in watts}}$$

$$\text{or} \quad \frac{\text{cooling capacity in Btu/hour}}{\text{energy input in watts}}$$

- Very similar to COP, except that EER is a measure of cooling capacity.
- Higher EER values indicate greater efficiencies.

- Cooling COP can be calculated by dividing EER by 3.413 Btu/watt-hour:

$$\text{Cooling COP} = \frac{\text{EER}}{3.413 \text{ Btu/watt} - \text{hour}}$$

Note: water-source heat pump COP and EER do not include all fan or pump energy, only that portion to overcome internal resistance of heat pump.

Heating seasonal performance factor (HSPF)

$$\text{HSPF} = \frac{\text{total heat provided during season in Btu}}{\text{total energy used by system in watt} - \text{hours}}$$

- A measure of efficiency over an entire heating season. This takes into account the energy losses from cycling, frost build-up, and also the supplemental resistant heating used during defrost.
- Building heat requirements and the prevalent weather conditions influence HSPF ratings. HSPFV (Region V) is a rating applicable to Canada. Higher ratings indicate more efficient heat pumps during heating season.

Seasonal energy efficiency ratio (SEER)

$$\text{SEER} = \frac{\text{total cooling provided during season in Btu}}{\text{total energy used by system in watt} - \text{hours}}$$

- This figure represents the cooling equivalent of HSPF.

Performance Standards

- Besides meeting the performance standards below, heat pumps are certified to meet the safety requirements of the Canadian

Standards Association (CSA) and Underwriter Labs (UL) in the U.S.

- The Air Conditioning and Refrigeration Institute (ARI) is the U.S. body that has established standards to rate heat pumps and compare efficiencies. Generally, methods of test are developed and published by ASHRAE.
- Ground-or water-source heat pumps have to meet additional requirements in Canada. These are:
 - CSA Standard C448 for installation and design practices of GSHPs.
- The above publication can be obtained from the CSA. There is no USA equivalent.
- The States, Provinces or Federal Governments regulate minimum efficiency of heat pumps. Other agencies have established high efficiency ratings. Refer to the following tables.

Table of CSA and ARI Standards for Heat Pumps

Heat Pump Type	Standard		Rating Point	Measured Variable	Temperature
	CSA	ARI			
Unitary Air-Source <65,000 Btu/h	CSA C656	ARI 210/240	Seasonal HSPF	-	-
Through-the-Wall <30,000 Btu/h	CSA C656	ARI 210/240	Seasonal HSPF	-	-
Small Duct High Velocity <65,000 Btu/h	CSA C656	ARI 210/240	Seasonal HSPF	-	-
Water-Source <135,000 Btu/h	CSA C13256-1	ISO-13256-1	Heating Cooling	Entering Water Temperature	68°F 86°F
Ground and Groundwater Source <135,000 Btu/h	CSA C13256-1	ISO-13256-1	Heating Cooling	Entering Water Temperature	32°F and 50°F respectively 77°F and 59°F respectively
Unitary Air Source ≥65,000 Btu/h and <135,000 Btu/h	CSA C746	ARI 340/360	Heating Cooling	Entering Outdoor Air	47°F 95°F

6 Definitions and Standards

Unitary Air Source ≥135,000 Btu/h	CSA C746	ARI 340/360	Heating Cooling	Entering Outdoor Air Temperature	47°F 95°F
Direct Expansion Ground Source	CSA C748	ARI 810	Heating Cooling	Fluid Temperature in Tank	41°F 77°F
Packaged Terminal	CSA C744	ARI 310/380	Heating Cooling	Entering Outdoor Air Temperature	47°F 95°F
Single Package Vertical	CSA C746	ARI 390	Heating Cooling	Entering Outdoor Air Temperature	47°F 95°F

Table of CSA Design and Installation Standards

Heat Pump Type	CSA Standard	Title
Residential split system air source	CSA C273.5	Installation Requirements for Air-to Air Heat Pumps
Ground Source heat pumps	CSA C448	Design and Installation of Earth Energy Systems

Table of Heat Pump Efficiency Requirements

Type	Capacity	Minimum Efficiency	High Efficiency
Air-Source (Split System)	< 65,000 Btu/h	HSPF V = 6.7 SEER = 13.0	HSPF V = 7.1 (ES) SEER = 14.0 HSPF V = 7.4 (CEE) SEER = 14.0
Air-Source (Single Package)	< 65,000 Btu/h	HSPF V = 6.7 SEER = 13.0	HSPF V = 7.0 (ES) SEER = 14.0
	≥65,000 -<135,000 Btu/h	COP @ 8.3°C = 3.2 COP @ -8.3°C = 2.1 EER = 10.1	No Definition
	≥135,000 -<250,000 Btu/h	COP @ 8.3°C = 3.1 COP @ -8.3°C = 2.0 EER = 9.3	No Definition
	≥ 250,000 Btu/h	EER = 9.0 (no COP requirement)	No Definition
Air-Source (through-the-wall) Split	< 65,000 Btu/h	HSPF V = 6.2 HSPF V = 6.4 > Jan.23/10 SEER = 10.9 SEER = 12 > Jan.23/10	No Definition
Air-Source (through-the-wall) single package	< 65,000 Btu/h	HSPF V = 6.1 HSPF V = 6.4 > Jan.23/10 SEER = 10.6 SEER = 12 > Jan.23/10	No Definition
Packaged Terminal	All	COP=3.2-(0.026×Cap/1000) (new construction) COP=2.9-(0.026×Cap/1000) (replacement market) EER=12.3-.213×Cap/1000) (new construction) EER=10.8-.213×Cap/1000) (Replacements)	No Definition
Water-Source	< 17,000 Btu/h	COP = 4.2, EER = 11.2	No Definition
	≥17,000 -135,000 Btu/h	COP = 4.2, EER = 12.0	
Ground-Source	<135,000 Btu/h	COP @ 0°C = 3.1 EER @ 15°C = 16.2	COP @ 0°C = 3.3 (ES)

Notes: ES – Energy Star Program
CEE – Consortium for Energy Efficiency
HSPF V – heating seasonal performance factor for region V
Cap – rated cooling capacity in Btu/h

Estimating Energy Savings

Standard efficiency ratings (COP) of ground source heat pumps are based on steady-state operation at a single operating condition. Actual seasonal energy savings will vary depending on the local climate, the efficiency of the existing or alternative heating system, the costs of fuel and electricity, the size of the heat pump installed compared to the house load as well as the standard efficiency of the heat pump.

The seasonal heating energy savings presented here were calculated using a procedure very similar to that used for air-source heat pumps, taking into account industry-sizing practice and regional ground temperatures across North America. Since ground source heat pump systems have COP standard efficiency ratings, it was necessary to calculate heating seasonal performance to predict seasonal energy savings.

The accompanying map shows the different climatic regions in Canada and the United States. A table is provided with estimated seasonal heating energy savings with air source and ground source heat pumps. A ground source heat pump will yield savings that are greater than would be provided by an air-source heat pump. This is due to the fact that ground temperatures are higher in winter than air temperatures and also that in cold regions an air-source heat pump requires back-up heating from a furnace. As a result, a ground source heat pump can provide more heat over the course of the winter than an air-source heat pump.

Estimated Heating Savings (%) Compared to Electric Resistance Heating

Region	Air-Source Heat Pump		Ground Source Heat Pump	
	Low	High	Low	High
I	65	70	65	75
II	60	65	65	75
III	55	65	60	75
IV	50	60	50	75
V	40	50	45	70
VI	60	65	60	75
VII	30	45	40	70

For any region, the estimated savings depend on a number of factors. The standard efficiency of the heat pump (HSPF or COP), the match of heat pump capacity to the design heating load, the ground heat exchanger sizing for ground source heat pumps and occupant effects. These estimated savings are for initial application screening and more accurate estimates can be obtained from your contractor or utility representative following a heat loss and heat gain calculation.

Locate your state or province and your location on the accompanying map. Then select your region number. See the table above for an estimate of the heating savings compared to electric resistance heating from using a heat pump in your location.



7 WHAT IS THE DIFFERENCE BETWEEN TYPES OF HEAT PUMPS?

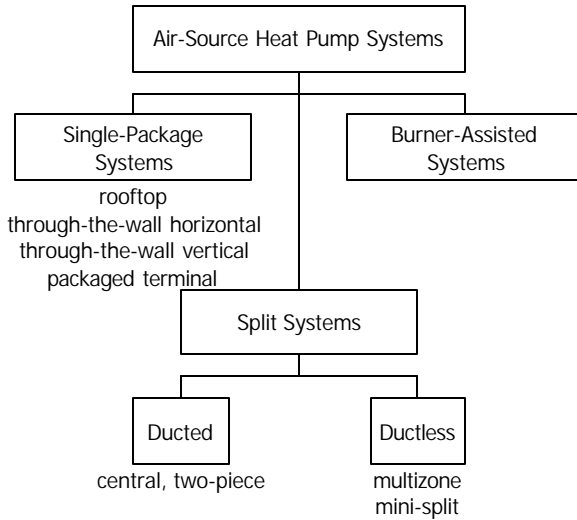

Air-Source Heat Pump Systems

7 What is the Difference between Types of Heat Pumps?

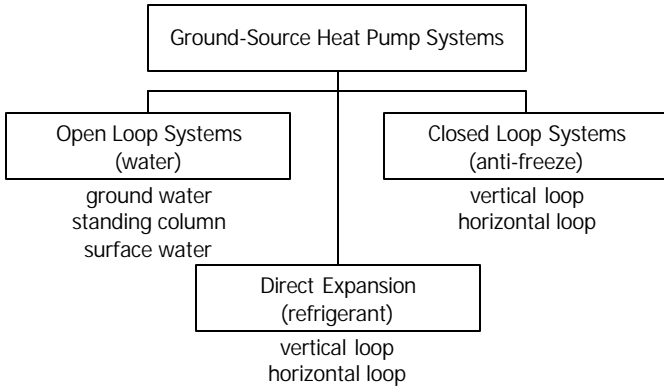

Ground-Source Heat Pump Systems

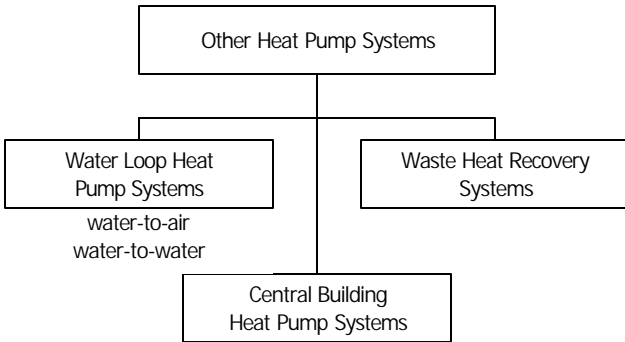

Other Heat Pump Systems

Problems with Classifications

- Many attempts have been made to classify heat pumps and this has produced a few discrepancies when naming them.
- Ambiguities arise because different methods of categorizing are used for air-source systems (based on the shape of equipment and number of boxes -single-package, etc.) as opposed to ground-source systems (based on layout within the heat source - vertical, horizontal etc.).
- The generic terms class, subclass and hardware are used to classify the various systems and equipment available.

System versus Hardware

- There is a difference between a heat pump and a heat pump system.
- A heat pump is the physical unit that performs the heating and cooling functions.
- A system is merely the definition or category of heat pump.

Variations of a Heat Pump

- Various types of heat pumps can be used in conjunction with an electric, gas or oil furnace.
- Using a heat pump with an oil or gas furnace as a backup heat source would be termed an oil-add-on or gas-add-on heat pump.
- A heat pump used in conjunction with an electric furnace would be termed an all-electric heat pump.

Air-Source Systems

- Air-source heat pumps are classified by:

7 What is the Difference between Types of Heat Pumps?

- type of equipment used;
- layout of equipment;
- method of distributing conditioned air.

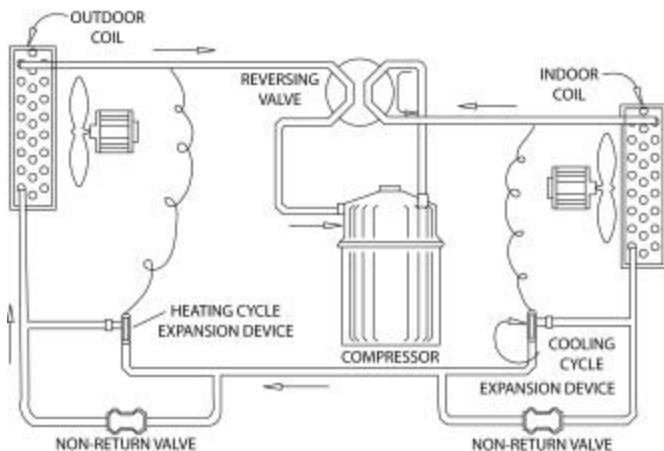

Figure 2: Air Source Heat Pump Component Diagram

Subclass: Single-package systems

Hardware: Rooftop (usually ducted)

Introduction

- All components of the heat pump are packaged into one unit.
- A number of units can be staged together to suit larger customer demands.
- Units can serve different zones with appropriate controls.

Technical Data (Units under 65,000 Btu/h)

- HSPF: 7.7 to 8.5

- SEER: 13 to 16
- Bels: 7.0 to 8.8
- Sizes: one to 5 tons.

Technical Data (Units over 65,000 Btu/h)

- COP: 3.2 to 3.4
- EER: 9.7 to 12
- Bels: N/A
- Sizes: 5 to 21 tons.

Applications

- Small commercial office buildings
- Shopping malls and plazas.
- Hospitals, schools and other institutions.
- New or retrofit applications.

Advantages

- Conditioned area is quiet because unit is located outside
- Can be installed quickly.
- Servicing is confined to a single area
- Units are similar to other heating/cooling rooftop units.

Disadvantages

- Need lifting equipment for installation.
- Entire system is inoperative if any malfunction occurs.
- Unit outdoors and inconvenient to service in winter.
- Requires defrost cycle and back-up heat.

Warranty

7 What is the Difference between Types of Heat Pumps?

- Compressor- five to 10 years.
- Coils -five to 10 years.
- Parts and labour are free for one to two years, depending on manufacturer.

Costs

- Two-ton unit -\$3,750 (approximately)
- Five-ton unit -\$6,500 (approximately)
- Ten-ton unit - \$13,500 (approximately)
- Curb and ductwork are extra.

Manufacturers

- Amana.
- Carrier.
- Armstrong.
- Lennox.
- Trane
- York International Ltd.
- ICP
- Rheem Manufacturing

Subclass: Single-package systems

Hardware: Through-the-wall or Packaged Terminal (usually ductless)

Introduction

- As the name implies, this unit sits in a wall with no ductwork.
- Similar in appearance to window air conditioners.
- Used for localized heating and cooling (e.g. one unit to a room).

- The backup heating for cold winter operation is supplied by built-in resistant heating elements or a water coil supplied by a boiler augment heat pump.
- Most units switch to back-up heat below the balance point.
- Through-the-wall available in horizontal and vertical.

Technical Data

- COP: 2.9 to 3.5 at 8.3°C (47°F).
- EER: 10.0 to 12.0.
- Bels: 6.5 to 8.0.
- Sizes: 0.5 to 2.0 tons.

Applications

- Hotels, motels.
- Small office buildings.
- Hospitals.
- Nursing homes.
- Apartments.

Advantages

- Can be used in new or replacement markets.
- Quiet.
- Does not require a refrigeration specialist to install.
- Can be replaced quickly by removing complete chassis of unit.

Disadvantages

- Limited use -only in buildings where each room or zone has an outside wall.
- Small cabinet size and poor airflow impact performance.

7 What is the Difference between Types of Heat Pumps?

- Defrost cycle and need for back-up heater.

Costs

- Half-ton unit - \$1,400 (approximately)
- One-ton units - \$1,800 (approximately).
- Two-ton units - \$3,500 (approximately).
- Wiring and ductwork are extra. Price dependent on manufacturer, dealer and location.

Manufacturers

- Carrier.
- Applied Comfort Systems.
- General Electric.
- McQuay.
- Amana.
- Friedrich.
- Islandaire.
- Bard.
- Skymark.

Subclass: Split systems

Type: Ducted

Hardware: Central two-piece

Introduction

7 What is the Difference between Types of Heat Pumps?

- Consists of an indoor and an outdoor unit each containing a heat exchanger coil.
- Can be used with vertical upflow, downflow or horizontal furnace or fan-coil indoors.
- Refrigerant piping connects outdoor and indoor units.

Technical Data

- HSPF: 7.7 to 10.5.
- SEER: 13.0 to 19.0.
- Bels: 7.1 to 9.0
- Sizes: 3/4 to 5.5 tons.

Applications

- Most commonly used for residential and small commercial applications.
- Retail stores.

Advantages

- Easy to install with new or existing warm-air furnaces.
- Reliable.
- Noise levels are usually fairly low.

7 What is the Difference between Types of Heat Pumps?

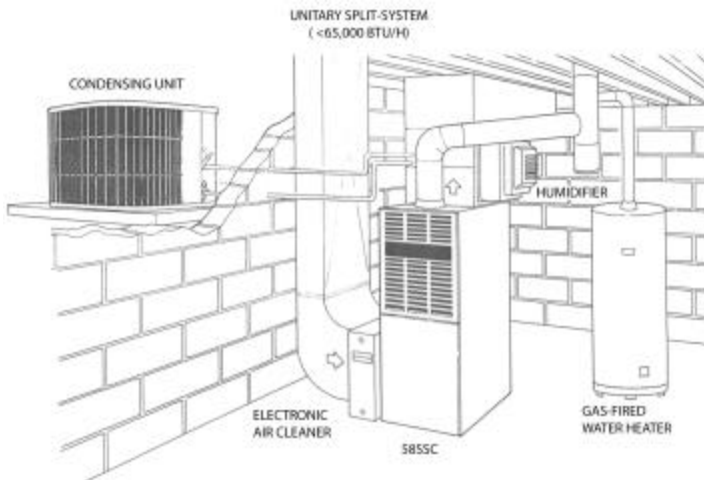

Figure 3: Split Heat Pump System Diagram

40

Disadvantages

- Requires refrigeration specialist to install.
- Unit outdoors exposed to elements.
- Defrost needed and requires back-up heat - both effect efficiency.

Costs

- \$1,000 plus \$1,000 per ton of capacity, installed.
- Prices vary by features, area, dealer and manufacturer. Back-up heat not included.

Manufacturers

- Amana.
- Carrier.

- ICP.
- Lennox.
- Trane
- York International Ltd.
- Armstrong
- Goodman Company
- Rheem Manufacturing

Subclass: Split systems

Type: Ductless

Hardware: Multizone or Mini-Split

Introduction

- Outdoor unit consists of compressor, controls and coil.
- Indoor unit consists of a coil connected to outdoor unit by refrigerant piping.
- Multizone heat pumps can have up to five indoor units connected to one outdoor unit.
- Indoor units are wall or ceiling mounted.
- All indoor units must be on the same mode (heating or cooling) at any time.

Technical Data

- HSPF: 7.0 to 10.0.
- SEER: 10.0 to 13.0
- Bels: N/A.
- Sizes: One to four tons.

Applications

- Homes with hydronic heating.

7 What is the Difference between Types of Heat Pumps?

- Small commercial.
- Special applications such as computer rooms or conference rooms.

Advantages

- Allows people to select individual temperatures for each room or area.
- Only uses the capacity of the system that is required.
- Very quiet.
- Good for retrofitting older buildings where installation of ductwork may be prohibitively expensive.

Disadvantages

- Higher initial costs than other systems.
- Lower efficiency due to cabinet size constraints and refrigerant line loss.
- Unit outdoors and requires defrost cycle – effects efficiency.

Costs

- 1.0 ton - \$3,315 (approximate)
- 1.5 ton - \$3,975 (approximate)
- 2.0 ton - \$4,955 (approximate)
- 3.0 ton - \$8,230 (approximate)

Manufacturers

- Carrier
- Mitsubishi Electric Sales
- Sanyo.
- Enviromaster International

Subclass: Burner-assisted (bivalent) systems

Hardware: Available in different configurations (single-package or split)

Introduction

- A conventional heat pump with a gas burner under the outdoor coil acting as a condensing gas furnace.
- Fuel supply can be propane or natural gas.
- Gas burner supplies auxiliary heat to building interior.
- Also supplies air conditioning during the summer.
- Gas burner operates when temperatures go below 0°C (32°F).

Technical Data

- COP: 2.4 to 2.72
- EER: 8.6 to 8.8
- Bels: Varies
- Sizes: Two to 15 tons.

Applications

- Homes.
- Small commercial installations.
- Offices.
- Shopping plazas and retail stores.
- Computer rooms.

Advantages

- Very efficient because of combination of air-to-air heat pump with a high efficiency condensing gas furnace.
- Fuel supply is located outside. No combustion indoors.

7 What is the Difference between Types of Heat Pumps?

- Since gas is used during the coldest weather, this unit lowers demand on the electrical system during peak usage.
- Reversal of system during defrost is not required since gas flame is used for both auxiliary heat and defrosting of coil.

Disadvantages

- In the event of a very rare compressor failure, the entire system is inoperative.
- Unit outdoors
- Only one supplier

Costs

- Two-ton unit - \$2,615 plus installation.
- Four-ton unit - \$3,350 plus installation.
- Price may vary depending on dealer.

44

Manufacturers

- Kool-Fire Ltd.

Ground-Source Systems

- The following agencies can provide information on GSHP installations:
 - Canadian Geoechange Coalition
 - GSHP manufacturers and dealers
 - International Ground Source Heat Pump Association.
 - Geothermal Heat Pump Consortium.
- CSA Standard CSA C448 covers installation practices for GSHPs. There is no U.S. equivalent.
- Ground- or water-source heat pumps are unitary or self-contained units which are connected to either open- or closed-heat exchanger piping systems.

7 What is the Difference between Types of Heat Pumps?

- These heat pumps incorporate a heat exchanger that allows the extraction or rejection of heat from/to the ground, groundwater or surface water.
- The fluid is water for open-loop systems and an antifreeze mixture for closed-loops. Closed loops operate at temperatures below freezing during the heating cycle.
- A more recent development has been the direct expansion (DX) ground source heat pump that works in a similar fashion to conventional GSHPs, except that a secondary fluid is not required. Copper pipes buried in the ground connect with the heat pump's refrigerant circuit and refrigerant is circulated directly. This development claims to reduce costs as the ground loop is now more efficient so less loop length is required for any given application.
- There are now some restrictions on the placement of copper loops in lakes. Consult your local provincial Ministry of the Environment or Natural Resources office for applications involving lake loops.

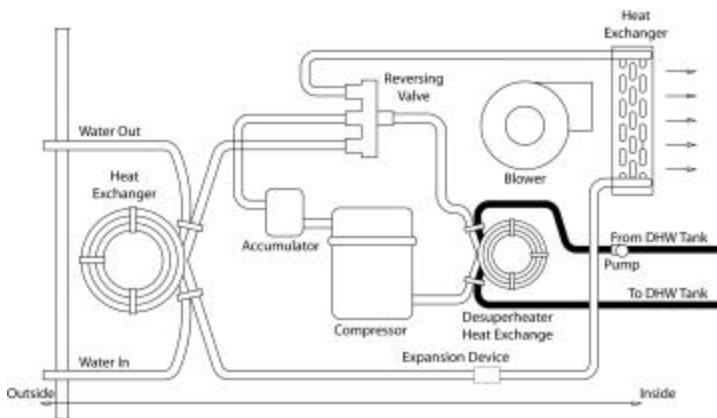

Figure 4: Ground Source Heat Pump Component Diagram

7 What is the Difference between Types of Heat Pumps?

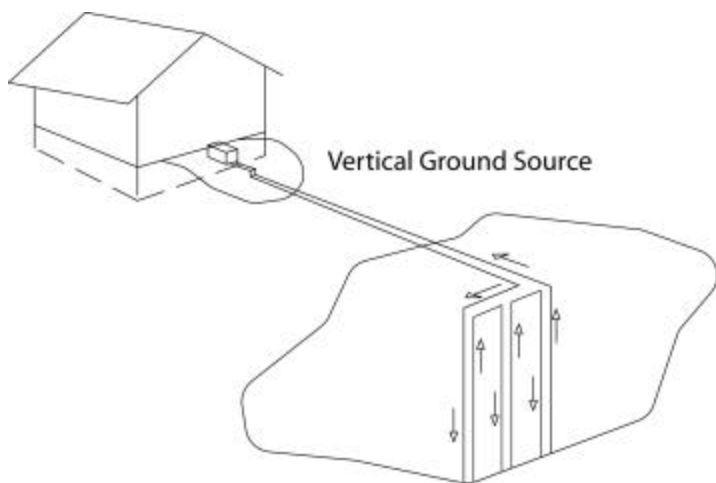
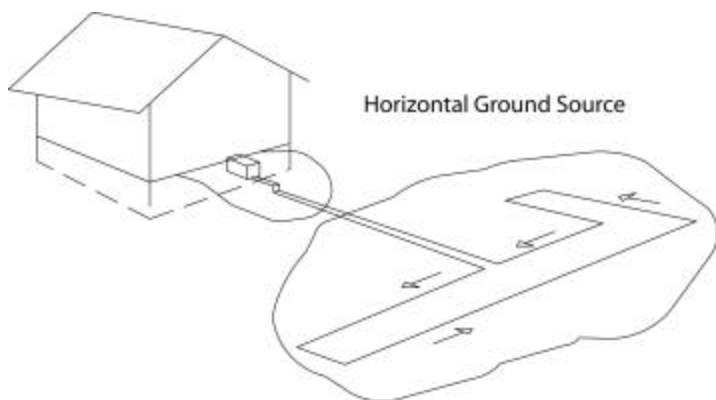

Figure 5: Types of Ground-Source Heat Pump Systems

7 What is the Difference between Types of Heat Pumps?

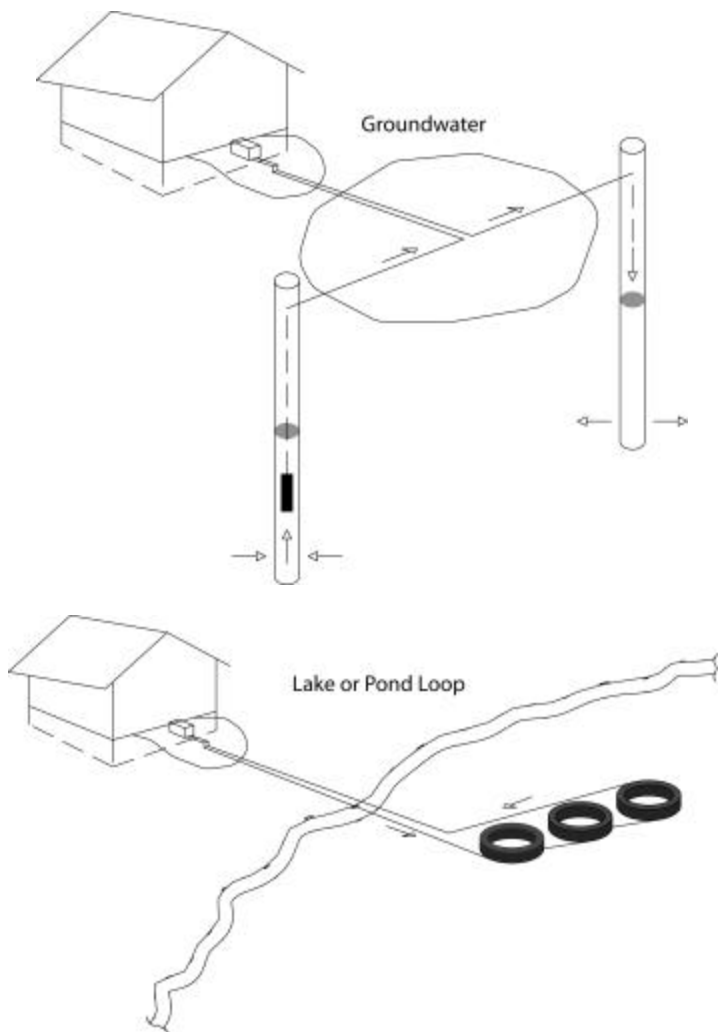

Figure 5: Types of Ground-Source Heat Pump Systems (continued)

Subclass: Open-heat exchanger systems

Hardware: Ground water or surface water

Introduction

- Uses groundwater or surface water as a heat source.
- During heat pump operation used water is disposed of through a re-injection well. Heat can also be rejected to the incoming domestic water supply for the hot water tank to reduce energy costs.
- Required water flow through the system depends on the size of heat pump (1.5-2 US gallons per minute /ton).
- Larger installations may require the use of multiple units.
- Some heat pumps have economizer cycles that allow cool water to circulate through a water-to-air exchanger in the ductwork. This provides cooling without using the compressor, if the ground-water temperature is low enough.
- A special case is the standing column well. One very deep well is used for both supply and return.

Technical Data

- COP: 3.0 to 5.0
- EER: 16.0 to 30.0
- Sizes: Up to 11 tons.

Applications

- Residential (primarily)
- Small commercial buildings.

Advantages

- Very economical.
- No defrosting required.

- Better performance than air-source and other ground source heat pumps.

Disadvantages

- Higher initial costs than air-source heat pumps.
- Some energy used for pumping water.
- Investigation needed before well development.
- Well production not known until well developed.
- Reliability depends on groundwater quality that can change over time.

Costs

- \$2,000 per ton of capacity plus installation, piping, well development and water pumps.

Manufacturers

- Climate Master.
- Florida Heat Pump
- Maritime Geothermal Ltd.
- Trane
- Enertran Technologies Inc.
- Waterfurnace International Inc.

Subclass: Closed-heat exchanger systems

Hardware: Vertical, horizontal or spiral

Introduction

- Heat exchangers are generally a parallel configuration. In parallel installations, pipe length for each branch should vary by no more than 5% to ensure equal flow.
- The total length of pipe installed depends on the required amount of heating and cooling, local climate, soil conductivity and lot

7 What is the Difference between Types of Heat Pumps?

size available. For example, 250 feet of trench per ton of capacity for 2-pipe horizontal heat exchangers and 140-300 feet of borehole per ton for vertical heat exchangers. Validated heat exchanger sizing software should be used to arrive at a final length.

- Horizontal heat exchangers can be coiled in a body of water (i.e. Lake loop) or buried in the ground. Several pipes can be buried in one trench with heat exchangers at an average depth of four to six feet, depending on location.
- The closed heat exchanger system reduces the need for large quantities of water.
- Rejected heat can be used for domestic water heating.
- Piping is usually high-density polyethylene plastic, although materials such as copper have been used in the past.
- Horizontal piping should be below frost line.

Technical Data

50

- COP: 3.0 to 4.5
- EER: 13.0 to 26.0
- Sizes: 0.5 to 11 tons
- Flow rate ranges from 2-3 GPM per ton of installed capacity.

Applications

- Residential
- Small commercial
- Schools.

Advantages

- No defrosting required.
- Very efficient.
- No outdoor equipment.

- Auxiliary heat not necessary but recommended.

Disadvantages

- Higher initial costs than other systems.
- Some energy used to pump fluid through heat exchangers.
- More complex than typical heating system.
- Limited number of qualified contractors.
- Design is complex compared to air source heat pumps.
- Indoor unit with compressor connected to ductwork can be noisy.

Costs

- Installed residential prices range from \$12,000 to \$18,000, depending on heat pump size, whether horizontal or vertical heat exchanger and amount of piping required.
- Initial costs are high but this is one of the most economical systems from an energy-use standpoint.

Manufacturers

- Climate Master
- Florida Heat Pump.
- McQuay.
- Enertran Technologies Inc.
- Waterfurnace International Inc.

Subclass: Direct expansion (DX) systems

Hardware: Vertical or horizontal

Introduction

- DX ground-source heat pumps are available in Canada. These units are similar in operation to the conventional, closed-loop

7 What is the Difference between Types of Heat Pumps?

GSHPs that use a secondary fluid (antifreeze solution) in the loop to transfer the heat.

- DX systems do not have a secondary fluid circulating pump. Copper pipe is buried in the ground that is connected directly into the refrigerant circuit of the heat pump. Refrigerant circulating directly through the copper ground heat exchanger transfers the heat.

Technical Data

- COP: Four or more
- EER: 12.0 to 16.0
- Sizes: One to five tons

Applications

- Residential
- Small Commercial.

52

Advantages

- No defrosting required.
- Very efficient.
- Unit indoors.
- Lower initial cost than conventional GSHPs since less loop is required in the ground for any given capacity, and a number of components have been eliminated.

Disadvantages

- Large quantities of refrigerant can be expensive.
- Qualified refrigeration mechanic must make final loop connections.
- If loop becomes damaged, it could be fairly costly to repair.
- Very limited number of suppliers and contractors.

- Indoor unit can be noisy.

Costs

- Significantly higher than conventional closed-loop.

Manufacturers

- Direct Earth Coupled Associates Inc. (DEC)
- ECR Technologies Inc.
- Maritime Geothermal Ltd.

Other Heat Pump Types

- Some heat pump systems collect heat from sources other than the ground, ground water and outdoor air.
- Common sources:
 - internal building heat
 - industrial processes (process water)
 - exhaust air.
- Integrated Systems
- Multisource Systems

Subclass: Water- loop heat pump systems

Hardware: Water-to-Air and Water-to-Water heat pumps

Introduction

- Uses a number of water-source heat pumps connected to a common supply-and-return water two-pipe system.
- More heat pumps can be added to the two-pipe system if required.

7 What is the Difference between Types of Heat Pumps?

- In the winter auxiliary heat is provided by a boiler to maintain the loop temperature lower limit. The boiler is sometimes replaced by a ground heat exchanger.
- At times during winter, heat rejected by units cooling internal core of a building is recovered by units heating perimeter.
- In the summer heat is absorbed by the loop and rejected to the atmosphere through a fluid cooler or a heat exchanger for preheating service hot water.
- Loop temperature is typically maintained between 60°F to 90°F.

Technical Data

- COP: 3.5 to 6.0
- EER: 10.0 to 19.5
- Sizes: Up to 10 tons.

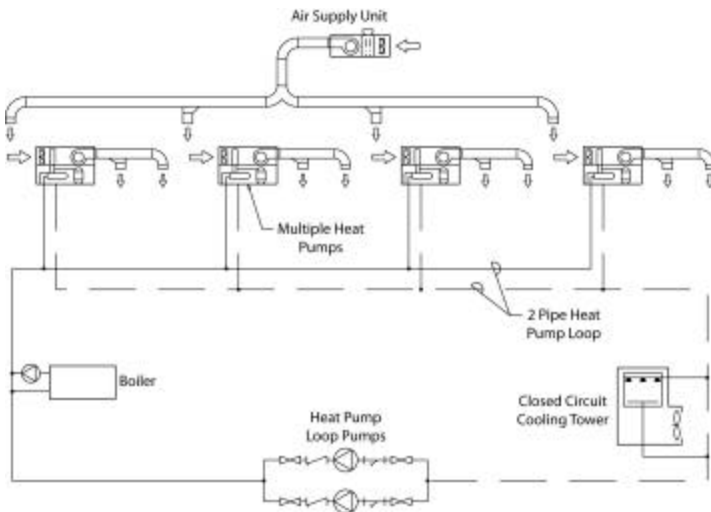

Figure 6: Water Loop Heat Pump System

Applications

- Apartment buildings.
- Office buildings.
- Shopping malls.
- Schools and institutions.

Advantages

- Complete zone control with simultaneous heating and cooling of separate areas with just a two-pipe distribution system.
- Less space required for mechanical rooms.
- Economical because of its ability to recover internal heat gains from lights, appliances, equipment, people and solar sources from one area to another (i.e. units in cooling mode provide heat for units in heating mode).
- If one heat pump fails, the rest of the system can still operate.
- Can be used with ground heat exchanger.

Disadvantages

- Treatment may be required for water in the loop.
- Makeup water is required for the cooling tower.
- More complex than typical systems.
- Needs building with co-incident heating and cooling loads to realize savings.

Costs

- 2 ton - \$2,200
- 3 ton - \$2,500
- 4 ton – \$2,900
- Not including interconnecting piping or ductwork.

Manufacturers

- Climate Master
- Carrier.
- Trane
- Florida Heat Pump
- Mammoth.
- McQuay
- Waterfurnace International Inc.

Subclass: Central building loop heat systems

Hardware: Positive Displacement or centrifugal heat pumps

Introduction

- Uses double- or split-bundle condenser working with reciprocating or centrifugal compressor.
- Transfers one area's surplus heat to another requiring heat.
- Hot water is provided as a secondary function at 100°F to 130°F.
- Can be used with a storage tank to store thermal energy.

Technical Data

- Each installation varies.

Applications

- Medium-to-large commercial buildings that require simultaneous heating and cooling.
- When the heat pump is used with a four-pipe system the sink and source of the heat pump are employed at the same time, increasing operating efficiency.
- Very effective when used in a well-insulated building.

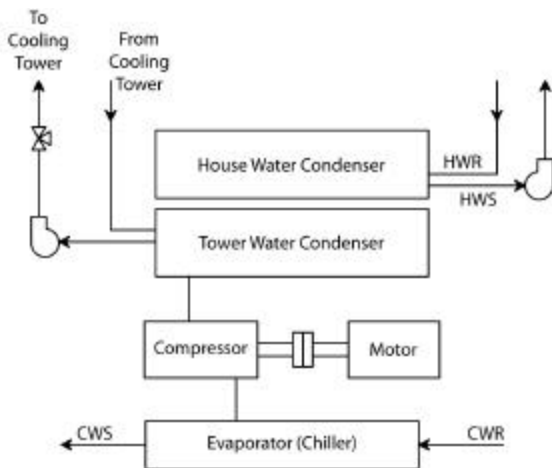

Figure 7: Central Building Loop Heat Pump System

Advantages

- Balances the heating and cooling loads in the building.
- Can be used with ground heat exchanger.

Disadvantages

- Low water heating temperature of 100°F to 130°F.

Costs

- Varies by installation. A guideline is \$2,800 per ton of capacity for a 50,000-square-foot or larger building. The cost will be higher for smaller applications.

Manufacturers

- Carrier.
- Trane.
- York International Ltd.

7 What is the Difference between Types of Heat Pumps?

Subclass: Waste heat recovery systems

Hardware: Special equipment

Introduction

- A majority of waste heat comes from industrial processes and building exhaust air.
- These systems provide hot water for makeup or hydronic space heating.
- Can supply process hot water up to 75°C (167°F).

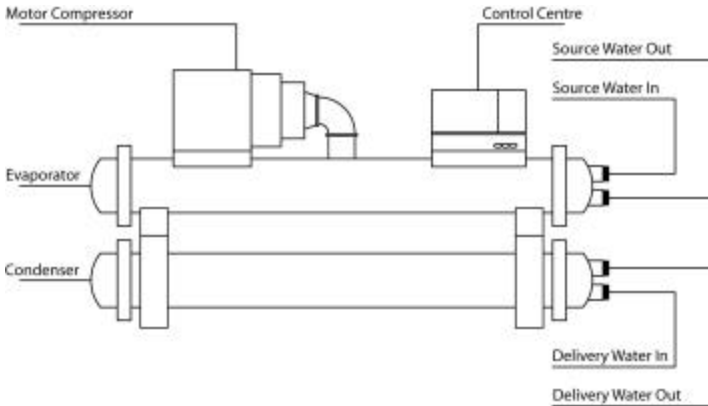

Figure 8: Waste Heat Recovery Heat Pump System

Technical Data

- Each installation varies.

Applications

- Large institutional buildings.
- Large office buildings.

- Factories.

Advantages

- The closer the difference between the source temperature and the final delivery temperature the more efficient the system.
- A high-use factor (hours of operation per year) will improve payback.
- Recaptures heat that would otherwise be wasted.

Disadvantages

- High initial investment required.

Costs

- Varies from installation to installation. Guideline is \$3,000 per ton of capacity for buildings over 50,000 square feet.

Manufacturers

- Carrier.
- Trane.
- York International Ltd.
- McQuay International

Integrated Systems

- Integration of different heating and cooling functions in one system, rather than separate systems, is likely to be the trend in the future. Heat pumps are well suited to integrated systems.
- The simplest form of an integrated heat pump system is a heat pump equipped with a desuperheater for water heating. Three separate functions can be served by one machine - space heating, space cooling and water heating.
- Another example is a dedicated heat pump water heater. The unit's evaporator cools indoor air before exhausting outdoors,

7 What is the Difference between Types of Heat Pumps?

providing ventilation with heat recovery as well as domestic water heating cool house air.

- In commercial or institutional projects, water-to-water heat pumps are often used in conjunction with energy recovery heat exchangers. Exhaust air passes through the heat recovery ventilator where energy is recovered. The incoming fresh air passing through the energy recovery device is heated to an acceptable temperature before supplying it to the heat pump inlets or directly to the occupied zones.
- Integration of systems reduces mechanical equipment duplication, and has positive impacts on equipment size resulting in both lower system and operating costs.
- In ground source systems, integration of systems helps to balance loads on ground heat exchanger and reduces cost of heat exchanger.

Multi-Source Systems

60

- Can be used to recover heat from several sources, such as kitchen and laundry (washers and dryers) exhaust.
- For these systems to work efficiently, there has to be a coincident demand for the recovered heat (e.g. requirement for domestic or process hot water).
- Solar equipment can be used with these systems. Collectors are hooked up to one or more hydronic heat pumps that are usually connected to a solar energy storage tank. Some solar systems are direct, with the refrigerant passing through the collectors. Of course, solar systems are better suited to certain applications (such as commercial buildings) as the higher initial cost (when compared to a similar air-source heat pump) can produce a longer payback period.
- Another example is a ground source heat pump combined with an outdoor air coil. During mild weather, the outdoor air can be used to warm the ground. This can be accomplished by simply integrating an air-coil into the ground loop.

8 INSTALLATION CONSIDERATIONS

Air-Source Heat Pumps

Selection

- Select a unit with as high an HSPF Region V as practical.
- If units have comparable HSPF Region V ratings, go with the unit with the higher rating at -8.3°C .
- Demand defrost control minimizes defrost cycles and improves system performance.
- Select a unit with an outdoor sound rating of 7.6 bels or lower.
- Consider a two-stage heat pump for better heating performance.

Sizing

- Select a heat pump to provide no more than 125 % of the design cooling load unless a two-stage unit is selected.
- Design cooling load should be determined using a sizing method such as CSA-F280 "Determining the Required Capacity of Residential Space Heat; and Cooling Appliances." In the US use ACCA Manual J.
- A properly sized unit will have a balance point between 0°C and -5°C .

Other Installation Considerations

- Locate the indoor coil downstream of any fossil fuel furnace.
- Locate the indoor coil upstream of any electric furnace.
- Locate the outdoor unit where winds, overhangs, drifting snow and roof drip-lines will not create problems.
- Mount the outdoor unit 30 to 60 cm (12 to 24 in) above grade on a suitable slab-mounted frame, or alternatively on a frame mounted from the wall of the building.

8 Installation Considerations

- Ensure that indoor coil condensate is piped to an interior floor drain.
- Allow sufficient space for service access around the outdoor unit.
- Keep refrigerant lines short and straight.
- Locate the outdoor unit where fan and compressor noise will not be an issue with neighboring buildings.
- Ensure all controller set points are properly adjusted for the installation.

Ground-Source Heat Pumps

62

Selection

- Select a unit with as high a heating COP at 0°C entering liquid temperature as practical.
- Select a unit with a desuperheater for domestic water heating. Note that in colder climates this will increase heat exchanger requirements because load is significantly imbalanced between summer and winter.
- Consider the use of a supplementary boiler to augment the thermal capacity of the ground heat exchanger reducing the cost of the system.

Sizing

- It is not generally a good idea to size the heat pump to provide all the heat required by a house.
- Size the unit to meet 70% of the total space heating and water heating design loads.

- The ground heat exchanger should be sized such that the ground temperature does not cool down or heat up over time. Computer programs are available that evaluate long term effects of heat exchanger sizing

Other Installation Considerations

- Ground source heat pumps involve more than one trade. Consult a contractor who can not only install the heat pump(s) but also can install or subcontract the installation of the ground heat exchanger, as well.
- The design and installation should be done in accordance to CSA-C448.2 (Residential) and CSA-C448.1 (Commercial). There is no USA equivalent standard.

What can go Wrong with a Heat Pump?

Heat pumps are unlike other comfort systems. This section covers problems that can occur and the most likely cause(s) of the problem.

Inadequate heating or cooling

- Low refrigerant charge, heat pump undersized, airflow rate too low, water flow rate too low (ground source), undersized ground heat exchanger (ground source).

Unit not operating in heating

- Low pressure lock-out (caused by low water flow rate (ground source), outdoor fan failure (air source)).
- High pressure lock-out (air flow rate too low, air filter needs changing, refrigerant over-charge).
- Sticking reversing valve.
- Compressor failure.

High Heating Cost

- Heat pump not operating in heating (see above).

- Improper control settings (particularly those interfacing operation of heat pump and back-up unit).
- Thermostat tampering (frequent raising and lowering of space temperature).

Low supply air temperature at grilles

- Characteristic of heat pumps – lower temperatures are normal-but indoor airflow rate may also be excessive.

Unit Over-sized

- Heat pump on cycles are short, reduced ability to dehumidify space, degraded efficiency, shortened equipment life.

Ice build-up around outdoor unit

- Inadequate elevation of outdoor unit (air source). In areas with significant snowfall proper drainage of defrost condensate is prevented allowing it to re-freeze on subsequent heating cycles.

Degrading performance with years

- Ground heat exchanger is too short for installation.

9 FREQUENTLY ASKED QUESTIONS

Do air source heat pumps make sense in areas outside major cities in the United States and Southern Canada?

Yes. While it is true that an air source heat pump's efficiency (COP) trends lower as the outdoor air temperature drops, it is often more economically attractive in a colder area. The reason for this is that the heating requirements are greater in the colder area than in a milder area. Even though the average heating COP is somewhat lower, the actual heating energy and heating operating savings are greater. An exception to this would be in the Canadian prairies and neighbouring U.S. border states (Region VII on map) where winters are extreme.

Does it make sense to operate an air source heat pump below 0 °C or should I just use my back-up furnace under these conditions?

Today's air source heat pumps are very efficient even at outdoor temperatures well below 0 °C. They are also able to operate over the full range of outdoor temperature in most USA and southern Canada cities. Whether you operate the heat pump in conjunction with the furnace or just the furnace depends on the relative efficiency of the furnace and heat pump at a given temperature and the cost of fossil fuel and electricity. It isn't just temperature dependent.

If I add a heat pump to my existing furnace, will it extend the life of my furnace?

Yes. The heat pump in an add-on system operates to provide about 70%-80% of the heat required by a house. The furnace provides the remaining 20%-30% of the heat. Since the furnace is operating far fewer hours its useful life should be extended.

Is there a Guideline or Standard for installation of heat pumps?

Yes. The Canadian Standard Association has developed two documents that provide a basis for proper design and installation of ground source heat pumps and air source heat pumps. The former is CSA-C448, while the latter is CSA-C273.5. There are no USA equivalent Standards.

How much land area is needed for a ground-source heat pump heat exchanger?

For a typical, 2 pipe per trench horizontal heat exchanger, the surface area required is about 2000 ft² per ton of installed heat pump capacity. For a vertical heat exchanger about 275 ft² per ton are required. This assumes that each borehole is deep enough for one ton. This is based on 150 feet per ton (typical of southern Ontario). Where drilling conditions make this depth impractical the required surface area per ton is 275 times the ratio of the required depth over the achievable depth. Horizontal heat exchangers are generally lower cost than vertical heat exchangers.

10 HEAT PUMP TRAINING PROGRAMS

- Heating, Refrigerating and Air Conditioning Institute of Canada
 - 2800 Skymark Ave., Building 1, Suite 201, Mississauga, Ontario, L4W 5A6 1-800-267-2231, (905) 602-4700
 - Offers courses on many aspects of HVAC installations including building heat loss, heat gain, duct design. Heat pump selection and sizing is covered.
- International Ground Source Heat Pump Association
 - 490 Cordell South, Oklahoma State University, Stillwater, OK 74078-8018
- Air-Conditioning and Refrigeration Institute
 - 4100 N. Fairfax Drive, Suite 200, Arlington, VA 22203, (703-524-8800)
- Air-Conditioning Contractors of America
 - 2800 Shirlington Road, Suite 300, Arlington, VA 22206, (703-575-4477)
- Heat pump manufacturers
 - Most offer technical seminars on their particular brand(s) of heat pumps. Contact individual manufacturers for details (see Section 11).

11 MANUFACTURERS

- The following list of manufacturers should not be considered as a comprehensive list. The names and web addresses of the manufacturers were accurate at the time of printing and may change without notice.
- It is the responsibility of the user of this reference guide to fully investigate the products and manufacturers mentioned. CEATI, not being a designer or manufacturer of heat pump products, makes no representation of warranty express or implied, including but not restricted to implied warranties of merchantability and fitness for a particular purpose, or as to the fitness, design or capability of the material, equipment or workmanship in any heat pump product, nor any warranty that the product will satisfy the requirements of any law, rule, specification or contract. Neither CEATI nor any person acting on its behalf, assumes any liabilities with respect to the use of, or for damages resulting from the use of, any information, equipment, product, method or process disclosed in this guide.

11 Manufacturers

Amana Company L.P.

www.amana.com

Armstrong Air Conditioning Inc.

www.aac-inc.com

Bard Mfg Co.

www.bardhvac.com

Carrier Inc.

www.carrier.com

ECR Technologies Inc.

www.ecrtech.com

Friedrich Air Conditioning Co.

www.friedrich.com

Fujitsu General America

www.fujitsugeneral.com

Lennox Industries Ltd.

www.lennox.com

Maritime Geothermal

www.nordicghp.com

70

McQuay International

www.mcquay.com

Mitsubishi Electric

www.mesca.me.com

Rheem Manufacturing Co.

www.rheem.com

Sanyo Air Conditioning Products

www.sanyo.com

Skymark International Inc.

www.skymarkinternational.com

Trane Company

www.trane.com

Waterfurnace International Inc.

www.waterfurnace.com

York International Ltd.

www.york.com